

AlterKtion™



Installation manual and information booklet

**CAUTION! PLEASE READ THIS ENTIRE BOOKLET
BEFORE PROCEEDING WITH INSTALLATION**

Assembling the Components	2
Preparing your car for the installation.....	8
Installing the AlterKtion system.....	10
Installation tips and notes.....	17
Alignment and Explanations	19

Getting to know your new suspension



Shown above is the basic suspension kit, with the sway bar and wedge motor mount options. Actual parts may vary from picture.

Please heed the following warnings for your own protection.

Machined threads are much more sensitive than regular nuts and bolts - ALWAYS use anti-seize compound on any machined threads, such as the tie-rod adjusters, balljoints, and shock body threads.

The first step is to organize the sub-assemblies. Start with the shocks. First slide the locking ring on and screw it all the way down to the bottom, then do the same with the adjuster, with the raised shoulder facing up.



Next install the spring bearings if you opted to get them - first a "washer", then the bearing, then the second "washer". BE SURE TO PUT ANTI-SEIZE COMPOUND ON THE THREADS OF THE SHOCK BODY!!!!



Next, slide the spring on and insert the upper seat. Turn the lower adjuster up to bring it all together and you're done. As a rule of thumb, you should preload the spring 1.5" before installing them - this should get you close to the proper ride height, or at least a good starting point. Note - turning the spring seat does NOT increase the spring rate - it merely adjusts ride height of the car.

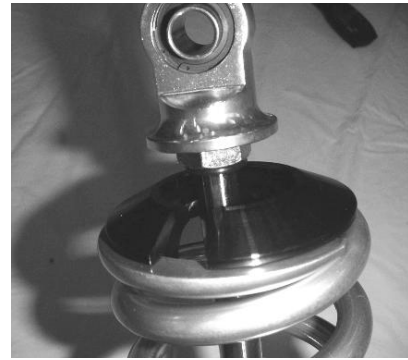

Find the four shock mounting bolts, and set them aside with the shocks.

Next locate all the steering parts as seen below. The power steering unit has similar parts.

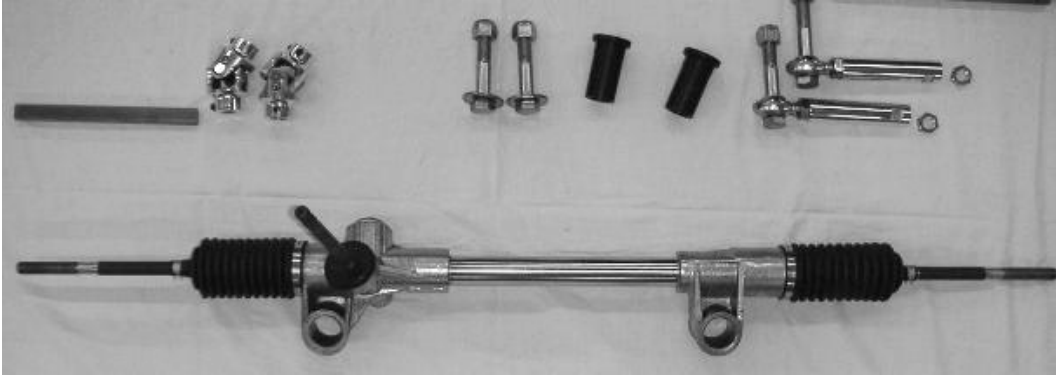

Place a small amount of lube on the rack bushings and install them from each side.



Rack Mounting Bushing



Rack Mounting Bolt

Install the bolts from the back, so the nut will be inside the mounting bracket on the K-frame.

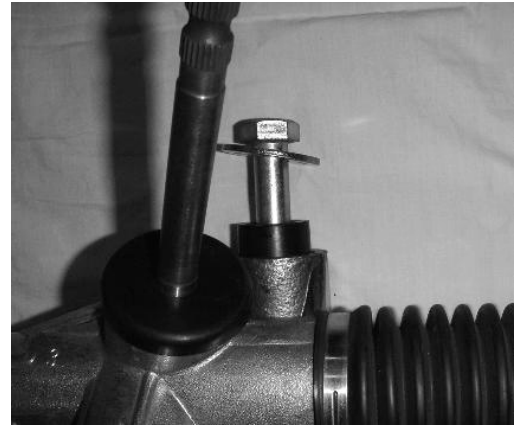

Next locate the tie rod ends. The ends are pre-assembled to make things easier, and only need to be threaded onto the ends of the rack tie rods.

First screw the jam nuts onto the rack ends, then the adjusters.

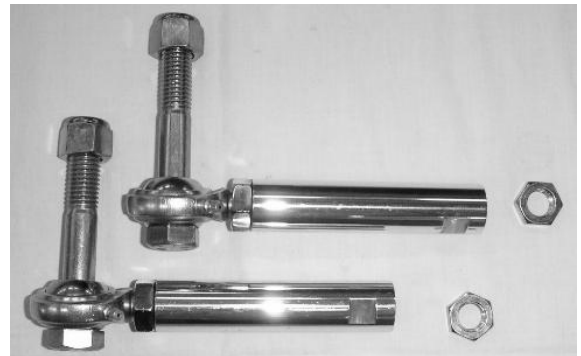

You'll also find in the same bag, the steering shaft and u-joints. For now, just put them aside with the assembled rack.



Next locate the lower pivot shaft components. You'll notice there's an extra bolt - this is for a reason, which we'll cover later.



Slide the 3/4" end caps onto the shaft with the recess facing out. Then put the 3/8" end caps on the ends with the bolts - these caps will capture the lower a-arm bushings when installed, preventing them from hammering out over time.



Assembled pivot shafts. The extra bolt and set screws will be covered during the install.



A few final items are the shock tower backing plates, two plates and four bolts, and the ends for the upper a-arms. Both of these are simple assemblies and are covered further during the install.

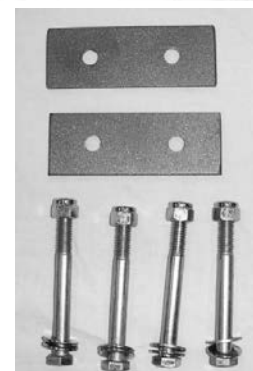

Options such as engine mounts and the sway bar are self-contained packages and will be covered later.

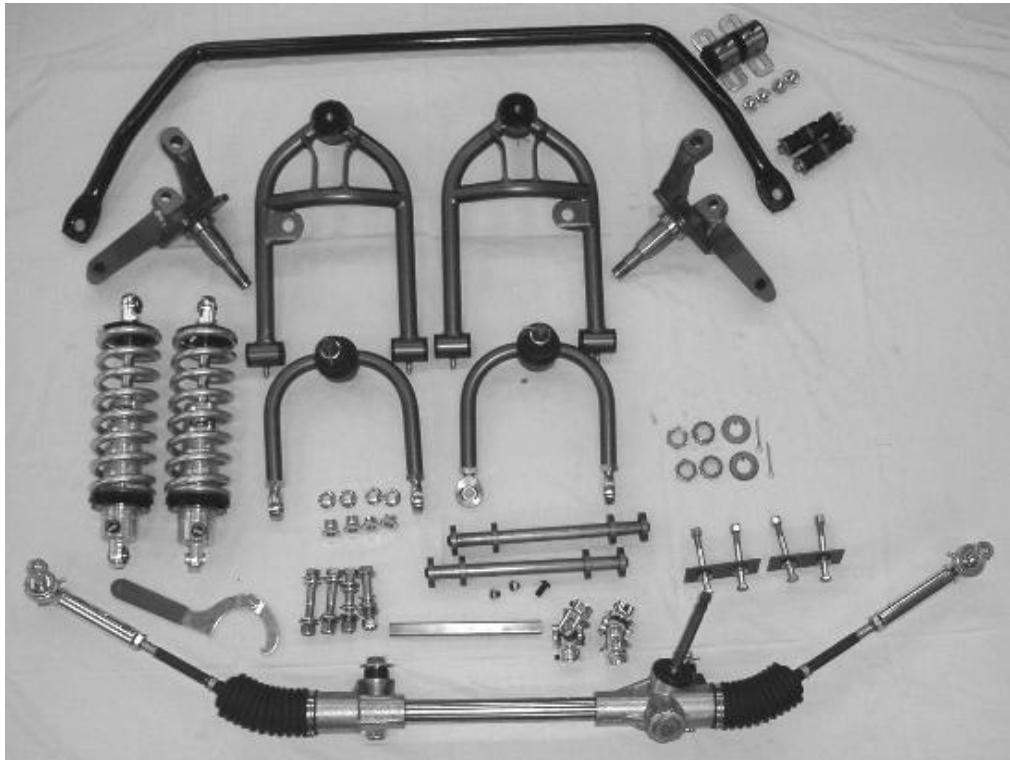

With all the sub-assemblies complete, everything makes much better sense, and will be quite a bit easier to install.

Preparing your car for the installation

1. It is unsafe to support engine/transmission assembly by a temporary means while doing this work. Engine/trans should be removed prior to removing the OEM suspension assembly unless motor plates, or elephant ear style mounts are used.
2. Support car using jack-stands. Place the stands BEHIND the front wheels, under the frame rails. You must have safe, unrestricted access to the entire K-frame assembly from the front and sides.
3. Remove wheels and tires. Completely back off torsion bar adjusting bolts to remove all tension. Remove the torsion bar retaining rings from the back of the transmission cross member. Remove torsion bars.
4. Remove rubber brake hoses and temporarily cap steel lines at frame (vacuum caps work well).
5. Remove upper shock attaching nut. Loosen and remove upper control arm eccentric bolts.
6. Disassemble coupling block on steering column.
7. If you have the equipment to handle this much weight, firmly support the K-frame assembly and remove the 4 K-frame bolts from the frame. Lower the entire OEM system to the ground and discard. If weight is a problem, see step 8.
8. Remove the outer tie rod ends and lower control arm attaching nuts. Remove each spindle/arm assembly separately, followed by the steering box/linkage assembly. Finally, support the bare K-frame and remove the attaching bolts. Lower the frame to the ground.
9. The only items you need to save are the upper control arm eccentric bolts, the 4 K-frame attaching bolts, and the pressed-in dowel pin in the steering column.

10. Using an electric drill with a 1/2" spot weld cutter, or 1/2" drill bit, drill out the 6 spot-welds holding the lower bumpstop bracket to the frame. Remove this bracket and discard.



On 62-72 A-body models, this is all that's necessary. On all other models, the upper bumpstop bracket must also be removed. A grinder or cut-off wheel can be used to grind most of the poor quality welds away. A simple twist with pliers is usually all that's needed to pull the bracket from the frame rail. This picture shows a 73-up a-body - both brackets must be removed. The

picture in step 11 is a pre-72 A-body - notice the upper bumpstop bracket clears the tower in these models.

11. At this point, the frame rails should be cleaned up. Trial-fit the AlterKtion frame, bolting it to the rails. Tighten all 4 bolts to be sure it fits correctly. Shock towers should slide up outside of frame rails. It's ok if the fit is slightly tight or loose, as the two attaching bolts will anchor the towers solidly to the frame rails to ensure a tight, secure assembly. Remove the AlterKtion frame and do any remaining cleanup on your stock frame rails.

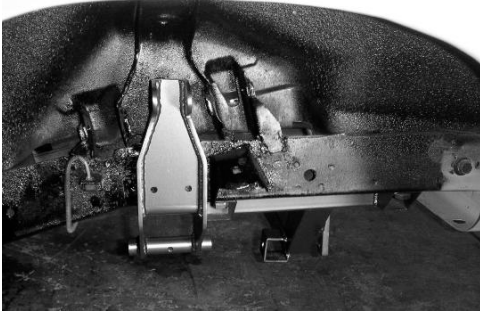

12. You are now ready to begin installing your system.

Installing the AlterKtion System

1. Slide the AlterKtion frame into place. The shape is awkward and we recommend



you have a buddy help raise the frame into position. Install your old K-frame bolts. The frame is designed for the OEM style bolts with the over-sized $\frac{3}{4}$ " shoulder. These bolts may be a tight fit, and they will pull the frame into perfect alignment with the car.

2. On the shock towers, you'll notice each tower has 2 - $\frac{3}{8}$ " holes. Using a $\frac{3}{8}$ " bit, drill these holes through the frame rails and install the supplied backing plates using the supplied $\frac{3}{8}$ " bolts. The backing plates are pre-drilled to the same spacing as the shock tower holes. It's difficult to hold a



drill perfectly straight to get through the interior side of the rails at the correct spacing. It's recommended you drill one hole straight through, install the bolt and backing plate, and then drill the interior side of the second hole from the engine compartment. Once installed, firmly tighten the bolts. Be careful to only tighten the bolts until the frame and shock tower are tightly together. Tightening too much can excessively crush the factory frame rail. The purpose of these bolts is to firmly hold the tower against the frame. No two cars are the same, and a means was needed to make up for irregularities in factory frame rails. In use, the forces on the shock tower hold it against the frame rail, they do not pull it away, so it's merely an added security, not a structural necessity.

3. Install the lower a-arms onto the frame using the supplied hardware. Both lower arms are identical. There is no right or left, unless you have the sway bar option - in that case, the sway bar brackets are on the front leg of the arm. The balljoint must point up. Place the 3/4" ID end caps on the inside bushing and slide the arm into place on the pivot tubes on the frame. The pivot shaft can be installed from either direction. Be sure to coat the shaft with anti-seize compound before



installing. An extra fastener is supplied, and should be installed loosely in one end of the shaft during assembly so the shaft is not damaged from hammering. With the shaft greased, they install quite easily. Once in place, remove the hammered fastener and use the 2 new ones to secure the 3/8" ID endcaps. Tighten the fasteners to 25lbs/ft. Thread locker should be used to prevent backing out. Next,

install the set-screw into the pivot tube and tighten to 25lbs/ft. It's good idea to use thread locker on the set screw.

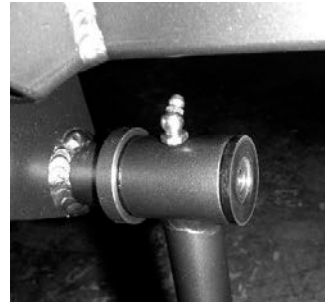

Finally, grease the ends. **GREASE UNTIL THE HANDLE STOPS - YOU'RE ONLY FILLING THE VOID INSIDE THE BUSHING END.** Periodically check to be sure the void is full - bushing life is drastically increased if the end is always full of grease. To remove the shaft if needed, hammer it out using a long pin. The best pin is a 3/8"X24 threaded rod that will screw into the end of the shaft, locked with a jam nut. This will prevent damaging the threads or the end of the shaft.

4. Install the assembled coil-over shock with the supplied 1/2" bolts.



5. Next install the spindles onto the lower a-arms. Steering arm must point forward. Install washer and retaining nut. Tighten to 50-60 ft-lbs.



6. Installing the tubular uppers works best by first installing it loose on the spindle to hold it in place while you fit the hardware into the frame rails. A good starting point for the rod ends is about 3 turns out.



7. Swing the arm into place and install the OEM eccentric bolts along with the supplied spacers. The longer spacers go towards the front, smaller spacers towards the rear, so the pivots are offset slightly towards the rear of the brackets. Also note - on all A-body models, some clearancing is required on the forward mount as shown.

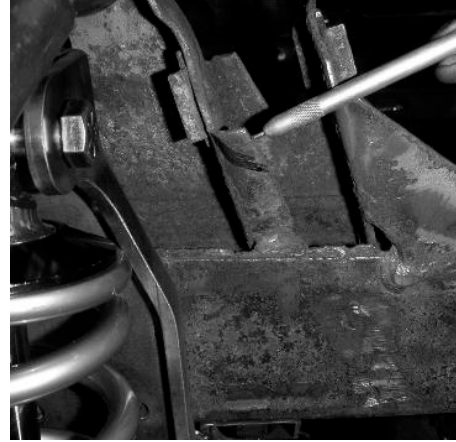

8. Next, install the rack and pinion assembly on the rear side of the cross-member. Use a washer on each side of the rack bushings – do not put a washer behind the nut.



9. Next, attach the tie rod ends to the spindles. The nut should be on top of the steering arm, the bolt inserted from the bottom-up.

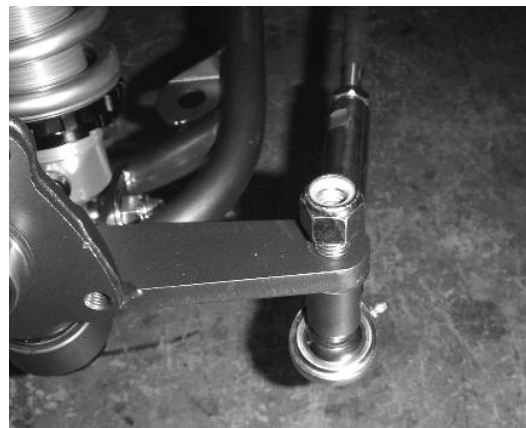

10. Slide one U-joint onto the steering input shaft and center the rack in its travel by hand. At this point, check your steering column for excessive play in the end. If your steering shaft is sloppy, see page 18 concerning other steps to take. The set-screw on the rack should seat in the notch between the two sets of splines on the input shaft. Tighten set-screw temporarily. Remove the press-fit pin from your factory column. Slide the pre-drilled, smoothbore u-joint onto the shaft. Do not re-install the pin yet. The supplied DD shaft is shipped extra long to allow for power/manual columns and chassis differences, so some trimming will be done before you secure everything.



11. With the column u-joint lined up with the hole, measure between the two joints. The



steering shaft protrudes into each u-joint 7/8". Add 1 3/4" to your measurement and cut the supplied shaft to length. Trial fit the shaft and joints to be sure of a proper fit. Be sure the steering shaft does not protrude passed the socket and into the universal joint area. This may cause interference and binding. Although not necessary, it's easiest to remove the steering column from the car to re-install the pin - it's a very tight fit and using a bench vice is much easier than hammering it while in the car. Shown below is the factory coupler alongside the new u-joint installed on the OEM column.

u-joint, with the solid pin from the end of the steering shaft. Also shown is the new u-joint installed on the OEM column.



12. Reinstall the column loose and attach the new steering shaft and rack u-joint to the end. Have a buddy line up the u-joint with the rack while you slide the column into place - taking care to ensure the steering wheel is straight. The end result is a clean-looking, and extremely strong steering assembly. A cosmetic note - the u-joints have long set screws and jam nuts - it's much nicer, and sometimes helps with clearance, if you trash the long set screws and get short ones that recess into the u-joint. Just use a little thread locker on them. Most fastener supply houses, like Fastenal, can get them in any size you like.



That's it for the basic install. See the following below for additional info on some of the options and other tips to make life easier.



Motor Mount Note

Although the engine mounts are a straight-forward bolt-on, some big blocks have abnormally large bosses on the driver side, making it necessary to do a slight clearance grind for the mount.

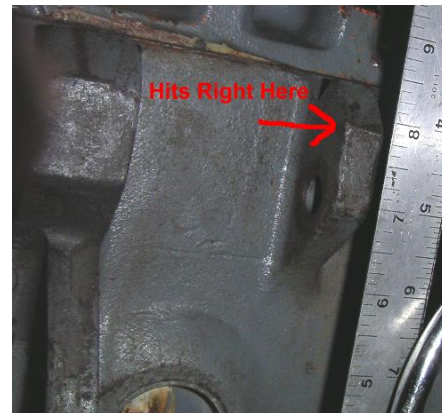
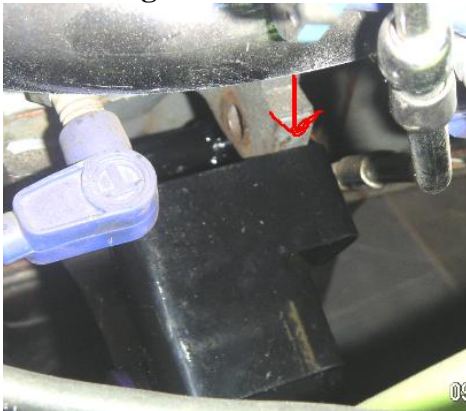

If you have this problem, grind the BLOCK, NOT THE MOUNT.

Sway Bar Installation

The sway bar is also a straight-forward install, with only a few comments to make.

The bar can be installed above or below the control arms by flipping it over. However It is very close to the coil-over when installed on top of the arm, so it's best to place it underneath, as shown in the pictures.



Steering Column Notes

In step 10 of the install, we mentioned steering column play. Pre-67 Mopars, 71-up B-bodies, and 70-74 E-bodies did not have a support bearing in the bottom of the steering column, and on many other cars, the OEM plastic bearing has simply fallen apart with age. We go over this during your order placement, so you may already have our Delrin support bushing. It gets installed in the end of the column as shown, preferably with red



thread-locker - it's nicer than drilling screws into the sides. It's also a good idea to shorten the outer housing of the column, so that only the steering shaft protrudes down into the engine compartment. This provides A LOT more clearance for the #7 header tube, and is a highly recommended modification while your car is apart. First, mark the housing near the firewall with the column in your car. Then simply take the column apart as per a service manual, cut the outer housing on your mark and re-assemble the column.

Obviously, column shift internals must be removed if you do this. If you have our support bushing to install, that's all that's required. If you have the factory bearing, you need to grind a notch to match the tab on the side of the bearing. Back in place, the housing is now out of the way, gaining you an additional 3/4" for header tubes.



Alignment Settings

Camber: Negative 0.5 degrees left and right side

Caster: POWER STEERING - Positive 4.5 degrees left and positive 5.0 degrees right
MANUAL STEERING – Positive 3.0 degrees left and positive 3.5 degrees right.

Toe-in: 1/16" total toe-in = 0.14 degrees = 0.07 degrees per wheel

Camber

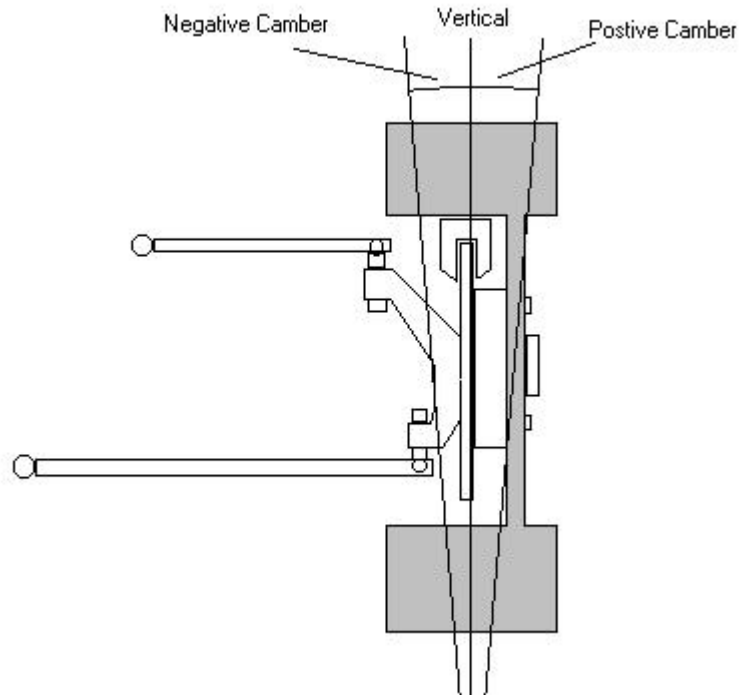

Camber is the inward or outward tilt of the spindle in relation to the **ground**.

Camber in theory, should always be zero to keep the largest possible tire surface area contacting the ground. Due to the fact that the vehicle leans in corners, and tire sidewalls flex, it's virtually impossible to achieve this at all times. In general, road course and autocross handling improves with as much camber as possible, 1+ degrees. However more than 0.5 degrees tends to excessively wear the inside edge of the tires. So for streetable cars 0.5 degrees is the max recommended.

Caster

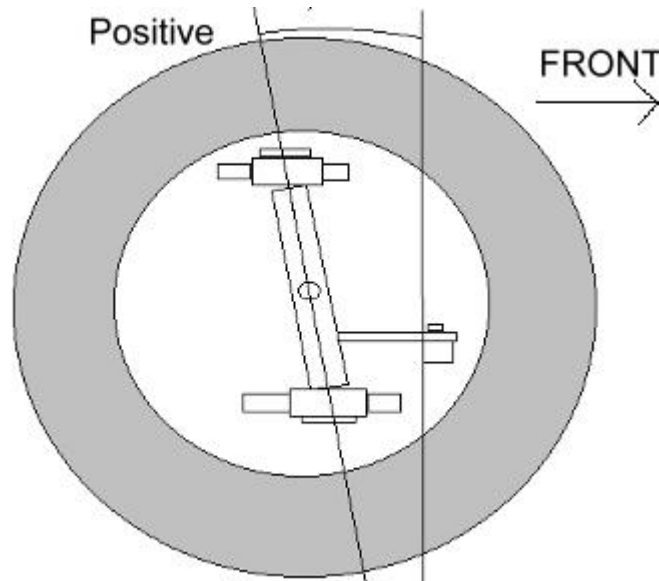

Caster is the forward or backward tilt of the spindle in relation to the ground. It also deserves a bit of explanation in regards to stability.

Positive caster has a stabilizing effect. When positive caster is used, the tire's contact area with the road is actually behind the lower ball joint. Since the weight on the tire is outside of the ball joints, both tires would pivot outward and back until they hit their stops. Since the wheels are connected with the steering linkage, these forces will cancel each other out when both wheels are straight. The greater the caster (within limits), the more force there is holding the wheels straight. The down side of this is increased feedback(vibration) through the system to the steering wheel. Power steering absorbs most of this feedback so more aggressive settings can be used with power steering. This feedback with manual steering is almost always greater than a vibration reducer can absorb, so it's best to simply keep caster in a reasonable range to avoid it.

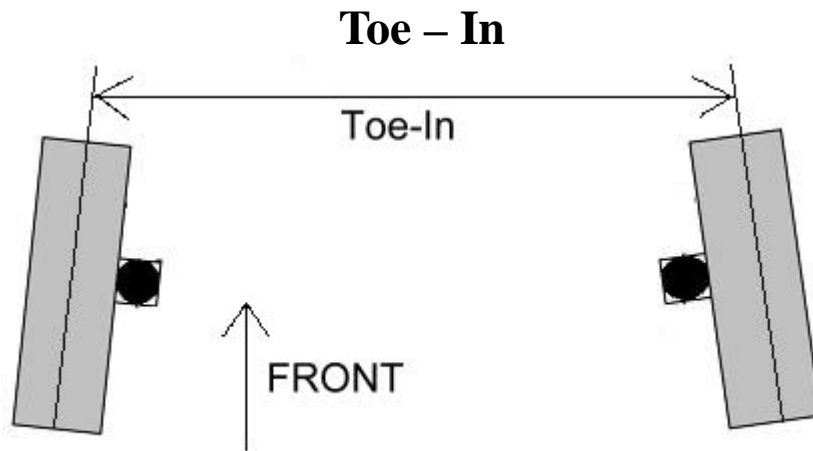

Both wheels should be parallel in a perfect world. However, bushing and chassis flex can cause the wheels to toe outward in many instances. Toe-out typically causes the car to wander, or dart around unexpectedly. Excessive toe-in increases rolling resistance and causes tire scuffing on the edges. Toe-in is another adjustment best kept to a minimum. The toe-in setting is used mostly to prevent the wheels from toeing out under any situation. Wheel assemblies with bushings tend to flex in operation while the steering remains rigid because it doesn't use bushings in its linkage. How much depends on the size, type, and number of bushings, as well as the tire diameter, the severity of the use and the overall weight of the vehicle. Aftermarket suspensions are typically designed with strong components and a minimum of bushings to prevent unwanted movement, so the toe setting is often less than most OEM cars.

Limitations

As with any performance product, there are some compromises to achieve bolt-on status.

In the case of this system, wheel backspacing is limited, depending on tire size.

The following numbers allow approx. 1/4" of clearance between the rim and tie rod end...

14" rim - 3.25" backspace maximum

15" rim - 3.75" backspace maximum

17" rim - 5.50" backspace maximum

18"+ rim - 6"+ backspace

Note - a 17" rim clears the tie rod end entirely, however with more than 5.50" backspacing, the rim may hit the tie rod at full lock in either direction. These figures are based on suspension clearance only.

There's no guarantee that a wider 17" rim, or the tires, will clear the frame rails or other parts of the car. Large wheels and tires typically require clearancing in other areas as well, and it is the owner's responsibility to determine the requirements of his/her particular situation.

As always, we're always happy to help or answer any questions you might have.

Disclaimer

Reilly MotorSports, Inc. cannot control how this product is installed or used. By purchasing this product, the buyer/end user assumes all risks associated with its use and agrees to having the proper skills for its installation. Reilly MotorSports Inc. and its suppliers will not be held responsible, liable or accountable for any injury, damage, loss, penalties, or fines that occur from using this product in any manner.