

- Please make sure all crimps are tight.
- Keep the wire length to a minimum for what is needed
- The blue and yellow crimp splices provided are heat shrink with low temp solder to give the best possible connection
- Check wires periodically after initial install

**WIRE DESCRIPTIONS:**

- 1) BLUE/WHITE - Passenger Side Fuel Level Signal
- 2) BLACK - Fuel Level Sender Common (GND)
- 3) BLUE/GRAY - Driver Side Fuel Level Signal
- 4) BLACK/ORANGE - Fuel Pump Common (GND) Not Used
- 5) BLUE/ORANGE - Fuel Pump +12V Power Long White from breaker

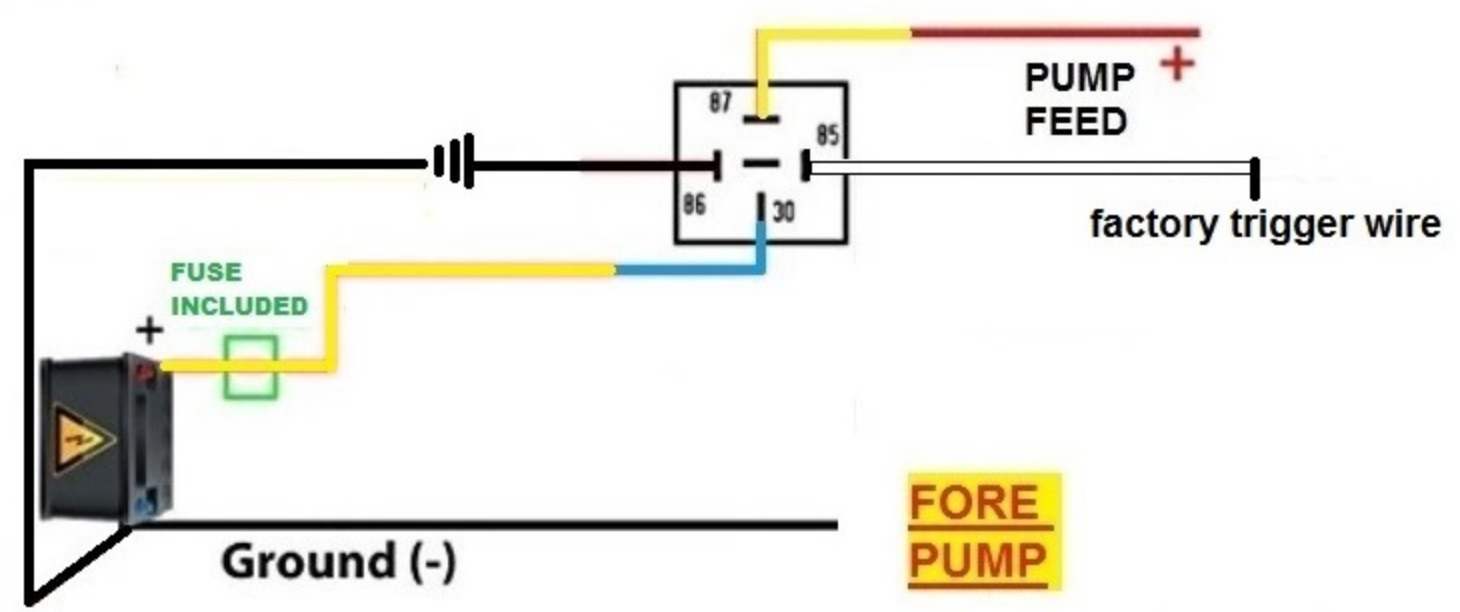

The blue (14ga) and the yellow (12ga) butt connectors supplied are crimp low temp solder shrink type follow instruction below

**Butt connector / Conector a tope / Manchon connecteur**

**INSTRUCTIONS / INSTRUCCIONES:**

1. Strip both wires 3/8" / Pelar el alambre de 9,5 mm / Dénuder le fil sur 9,5 mm
2. Insert wire into barrel / Insertar el alambre en el cuerpo cilíndrico / Insérer le fil dans le cylindre
3. Crimp wire to barrel / Engarzar el alambre sobre el cuerpo cilíndrico / Sertir le cylindre sur le fil
4. Heat tubing / Calentar la tubería / Chauffer le tube
5. Solder flows into barrel / La soldadura fluye en el cuerpo cilíndrico / La soudure s'écoule dans le cylindre



**In-Tank Connections;**

- The passenger side BLUE wire to fore GREEN
- One of the driver's side BLUE to fore YELLOW
- The remaining driver's side blue and passenger side black connect to the small black wire

**Out-Tank Connections; \*\*\***

- Fore GREEN to OEM plug (1) Blue/White
- Fore Yellow to OEM plug (3) Blue/Gray
- Fore Black(small ga.) to OEM Plug (2) Black

**Power Connections;**

- White wire in relay harness to OEM Plug (5) Blue/Orange
- Long RED wire 10GA in relay harness to Fore RED pump power on pump assembly
- **## inline fuse** in relay harness to Battery (+). Power lug located under the power distribution box lid behind the battery.
- The remaining black wires (grounds) both go to the grounding lug, located on the frame rail to the right of power distribution center behind battery. ## Note power wires and grounds can go directly to battery terminals if you so choose

**NOTE:**

The Driver side sending unit has 2 blue wires coming off it. One is the signal and one is the ground. The wire going to OEM Plug pin (3) is the signal wire and goes to the Yellow Fore wire. The other is the ground and tied in with passenger side sending unit ground both are tied together with the small black Fore sending unit wire inside tank and connected to OEM Plug pin (2).